



Rev. # 10-08

PART # CA2755L-3 INSTALLATION INSTRUCTIONS 1986 $\frac{1}{2}$ -1996 NISSAN PICK-UP LOWER CONTROL ARMS

Please take the time to read these INSTALLATION INSTRUCTIONS and check the Hardware Parts List to be sure you have all the listed parts BEFORE BEGINNING INSTALLATION .

DJM parts should be installed by qualified mechanics. If you are not familiar with automotive repair have the parts installed by someone with experience.

Please read the warranty information (blue page enclosed). Complete your Product Warranty Card and mail it to DJM Suspension.

Please take a few minutes to fill out your installation helper (back side of warranty). Accurate measurements BEFORE BEGINNING INSTALLATION will show any irregularities in your vehicle.

**NEVER WORK UNDER TRUCK SUPPORTED BY A JACK ONLY !!!
USE QUALITY JACK STANDS WHICH HAVE A RATING ADEQUATE FOR YOUR TRUCKS WEIGHT!!!**

THIS KIT DOES NOT INCLUDE NEW BALL JOINTS. YOU MUST REUSE OR REPLACE FACTORY BALL JOINTS.

NEW FRONT SHOCKS DJM PART # 1315 ARE RECOMMENDED. BUT NOT REQUIRED.

USING AIR BAGS WILL VOID DJM'S WARRANTY!!

INSTALLER MUST CHECK THAT THERE IS ABSOLUTELY NO CLEARANCE PROBLEMS BETWEEN THE WHEELS, THE SPINDLE, THE CALIPER, THE LOWER CONTROL ARMS AND ANY OTHER COMPONENT BEFORE DRIVING VEHICLE.

Hardware Parts List:

- 1- Right Control Arm.
- 1- Left Control Arm

1) Park your truck on flat level surface. Chock the rear wheels. Loosen front lug nuts. Raise the front with a floor jack. Support the frame with jack stands. Remove front wheels.
NOTE : ALWAYS USE JACK STANDS - NEVER RELY ON JACKS ONLY!!

2) Remove lower ball joint cotter pin and loosen nuts 2 full turns. Free ball joint from spindle using a pickle fork. Be extra careful not to damage ball joint or dust boot, you will need to reuse ball joint.

3) Starting on the drivers side, locate the height adjusting bolt at the rear of the torsion bar. Measure and record the length of the threads exposed between the end of the adjusting bolt and nut (Fig. A). Now make a mark at the front of the torsion bar, where it goes into the bracket bolted the lower control arm. Mark

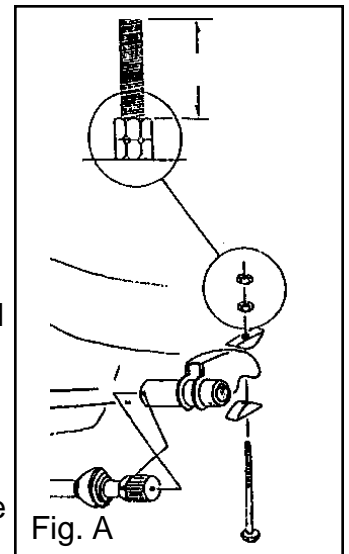

both the bar and the bracket (Fig. B). This will index the bar into the correct position when installing.

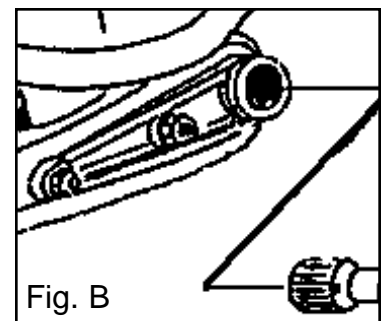

Note : Step # 3 assumes torsion bars are in the factory position.

4) Loosen the height adjusting bolts until there is no longer any load on the torsion bars.



PART # CA2755L-3

5) Remove the two bolts holding torsion bar assembly to the lower control arm. Slide the torsion bar and receiver away from the control arm. Repeat step #3 through #5 on passenger side.

6) Unbolt sway bar end link and remove lower shock bolt. Unbolt TC (Tension\Compression) rod. Remove ball joint nut. Remove pivot bolt and remove lower control arm. (Removal of plastic splash guard is recommended).

7) Remove rubber boot from ball joint on original control arm. Carefully remove the clip which secures ball joint and press out ball joint.

8) Press ball joint into your new DJM control arms. Install clip and rubber boot.

9) Install DJM control arm to frame using original hardware, but do not tighten. Make sure the short bolt next to pivot is inserted before attaching to frame.

NOTE: The steering stop on the control arm must be facing forward.

10) Bolt TC rod to control arm and tighten to factory specifications. Install ball joint to spindle, tighten and install new cotter pin.

11) Attach torsion bar assembly to control arm, making sure torsion bar is indexed in the same position as before. Torque bolts to factory specs. Now tighten all mounting hardware except for pivot bolts. Pivot bolts must be tightened after vehicle is on the ground.

12) Adjust height adjusting bolts to the original positions you documented in step #2 before disassembly. Do not tighten jam nuts.

13) Attach shock and sway bar end link, using original hardware.

14) Check brake lines for interference. Install wheels and torque lugs nuts. Check tires will turn both ways without making contact. Remove jack stands.

15) Now tighten pivot bolts.

16) Make any adjustment necessary to obtain desired ride height. Make sure truck is level from side to side. Tighten adjusting bolt jam nuts. Double check all hardware to be sure everything is tight. Check tires will turn both ways without making contact.

17) Take your truck for a test drive. Start off slowly and listen for any unusual noise.

18) After test drive, measure height of front and record on installation helper. Your measurements should be about 3" less than the before measurement. If not, readjust the height adjustment bolts.

TAKE YOUR TRUCK TO A QUALIFIED ALIGNMENT SHOP FOR A PROFESSIONAL ALIGNMENT.

