

Universal Lowering Block Instructions

Please read and understand the instructions before installing.

REV - 0316

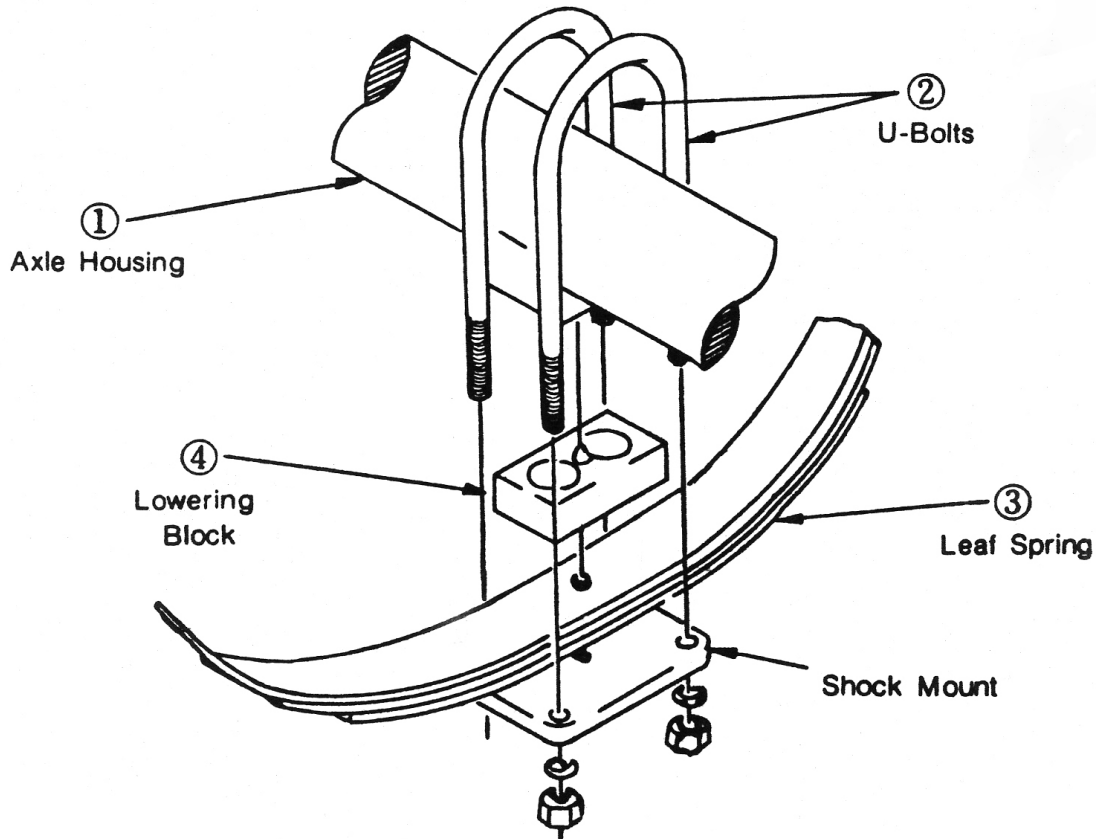

Step 1 - Important

For your safety be sure to use properly rated jack stands for your vehicle, don't rely on jacks alone.

Step 2

Working on one side at a time, loosen and remove the U-bolts (item 2). Using a hydraulic jack, raise the rear axle (item 1) away from the leaf spring (item 3) enough to place a lowering block (item 4) on the leaf spring below the axle housing. This moves the axle housing up and lowers your truck. Using your hydraulic jack lower the axle housing down being careful to make sure the block is centered on the leaf spring center bolt and the axle housing sits on the pin located on top of the block. Install the new U-bolts over the axle and through the shock mount plate. Using the lock washers and nuts provided tighten to 80 foot pounds. Congratulations! One side is done, now repeat the same steps on the other side and your lowering block installation is complete!!

TIP: Check the U-bolts/nuts after a few miles to make sure they are tight. The split washers included with the kit are lock washers but you can use a little "Locktight" or any thread locking compound for added security.

DJM Suspension
580 West 184th Street
Gardena, CA 90248

800-237-6748
310-538-1583
310-538-0393 (Fax)

www.djmsuspension.com
orders@djmsuspension.com
tech@djmsuspension.com