



PART# DB3004-3

DREAM BEAMS

INSTALLATION INSTRUCTIONS

The following steps are used for installing Part # DB3004-3

Before beginning installation, identify driver and passenger beam. Set both beams side by side with king pin ends together. The king pin receiver tube is welded at about a 5 degree inclination. Each beam, when installed, will have the top of the spindle tilted to the rear. Be sure to install on the correct side. The counter bore, split lock and nut faces to the rear of the truck

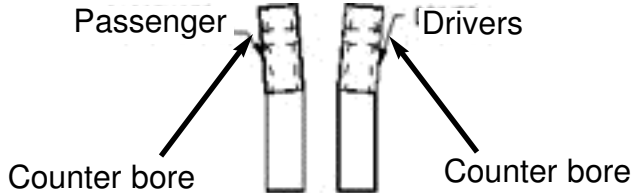

Before installing new DJM Dream Beam on you truck, take a minute to check the condition of king pins. Replace if necessary with the following numbers available at you local parts store. 1965-1974 Uses #8524 \ 1975-1979 Uses #8540. Inspect king pin receivers on the new beams. Look for excess paint build up in the tube, also check lock pin hole. Next insert king pin in hole and align lock pin notch with hole in beam and insert lock pin. Clean out excess paint if needed. Assemble spindle onto the new beams. Apply some grease to the red bushings and in the sleeve. Bolt on vehicle using all factory hardware.

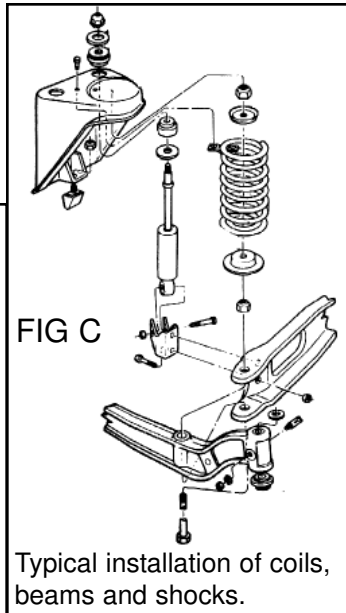
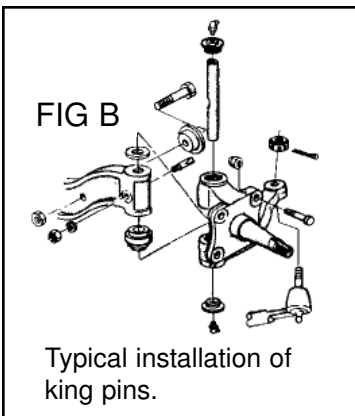

NOTE : 1966-1972 Drum brakes models only. You will need to reverse the bolts that hold the tie rod arm to spindle. This will give more clearance for the swing of the spindle. You will need to loosen hub assembly and move it out to remove factory bolt. Install nuts on inside. Be sure to install new cotter pins. See diagram below.

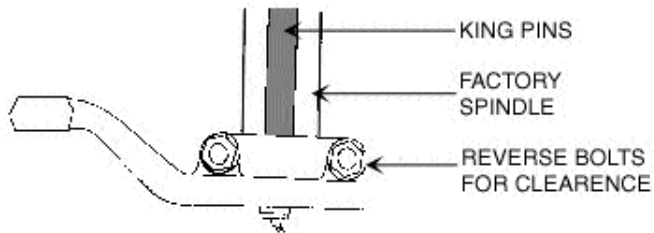

The counter bore, locking pin split lock and nut will face to the rear of the truck both sides

INSTALLER MUST CHECK THAT THERE IS ABSOLUTELY NO CLEARANCE PROBLEMS BETWEEN THE WHEELS, THE SPINDLE, THE CALIPER, THE BEAMS OR ANY OTHER COMPONENT BEFORE DRIVING VEHICLE.



TIE ROD EXTENSION BRACKET INSTALLED

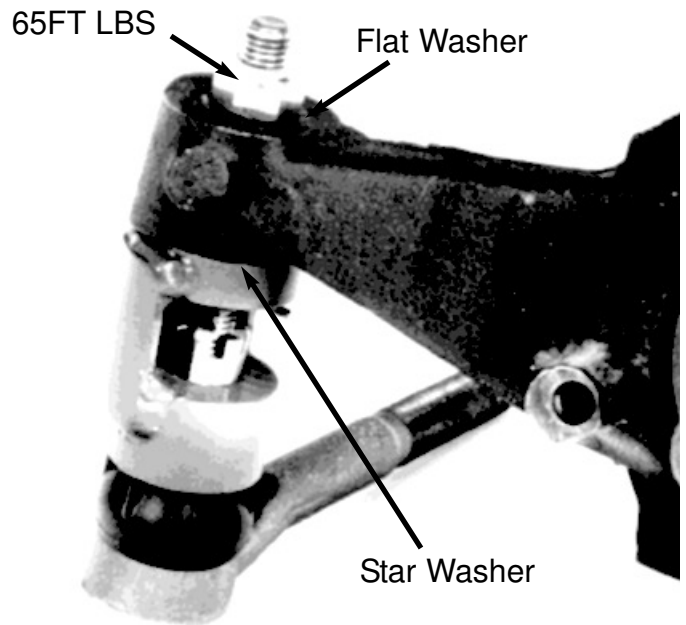

After installation is complete, and all components are checked for clearance problems, test drive vehicle. Align front end to factory specs.

Check out all the DJM products on the web www.DJMSuspension.com
Tech Line (310) 538-1583